

# **KLD Guitar AMP**

## **Uranus-5H(M)**

### **Tube Guitar Amplifier Manual**



**Kailing Electronic co.Ltd**  
**<http://www.kldguitar.com>**



Before printing this manual, assess if it is really needed



Intended to alert the user to the presence of un-insulated " dangerous voltage" within the product's enclosure that may be of sufficient magnitude to constitute a risk of electric shock to persons.

Intended to alert the user to the presence of important operating and maintenance (servicing) instructions in the literature accompanying the product

**CAUTION:** Before you "ON" Uranus 5HM, please ensure it has been connected with speaker. If not, it will damage tube and transform.

**CAUTION** Risk of electrical shock –DO NOT OPEN!

**CAUTION** To reduce the risk of electric shock, do not remove cover. No User serviceable parts inside. Refer servicing to qualified service personnel.

**WARNING** To prevent electrical shock or fire hazard, do not expose this appliance to rain or moisture. Before using this appliance, read the operating guide for further warnings

**Congratulations:** on your purchase of the Uranus 5HM. The Uranus 5HM is a Class A purpose-built recording head amplifier. A spring reverb provides natural sound. The single-ended Class A valve output stage allows the player to crank up the volume to the desired level-flat-out if necessary - to achieve just the right amount of compression and distortion without the acoustic output becoming annoying. The speaker emulating headphone output lets you practice and record without a speaker cabinet. You no longer have to worry about annoying the wife/flat mates/neighbours and restrict your recording time to moments when everyone is away! It can be connected to a cabinet with either 12 or 15 inch speaker cabinet.

## **FEATURES**

5 watts (RMS) 8 ohms

Tubes: one EL34 and two 12AX7's

Single End Class A

Standby

Toroidal Transformer

Output jack for external speaker: 4 ohms and 8 ohms. 2x8ohm, 2x16ohm

Hi-Lo impedance input

Controls: Gain, Reverb, Bass, Middle, Treble, Volume

Booster/Normal SW

Bright/normal SW

Head phone with emulator of speaker, Amp can be used only connecting headphone , don't need connect cabinet.

Spring reverb with control

XLR out

FS jack

FX LOOP (Send/Return)

Precision made parts used for lowest signal to noise ratio.

5W metal oxide power resistors. 600V polypropylene film/foil and polyester military capacitors



### 1. LED NORMAL/BRIGHT (1)

Switch to position "I" to activate;"O" to OFF

**2. NORMAL/BRIGHT: (2)**

Push for more bright sound

**3. LOW INPUT: (3)**

The Input jack will accept signals from low impedance guitar pickups, Be sure to use a high-quality shielded cable to connect the guitar to the amplifier

**4. HIGH INPUT: (4)**

The Input jack will accept signals from high impedance guitar pickups, Be sure to use a high-quality shielded cable to connect the guitar to the amplifier

**5. GAIN: (5)**

Preamp gain control

**6. REVERB ON/OFF: (6)**

On/ OFF spring reverb .

**7. REVERB: (7)**

Reverberation is an echo effect. Rotate clockwise to increase the effect

**8 BASS: (8)(EQ)**

Passive tone controls that regulate high, mid, and low frequencies respectively

**9. MIDDLE: (9)(EQ)**

**10. TREBLE: (10)(EQ)**

**11. BOOST SWITCH: (11)**

“Boost”The overall system gain; Depress to the “in” position to activate

**12. VOLUME: (12)**

Controls amp volume

**13. STANDBY (13)**

When you on the amp, open power switch first, after 30-60s, open standby. When you off the amp, close standby first, then close power switch.

**14. LED OF STANDBY (14)**

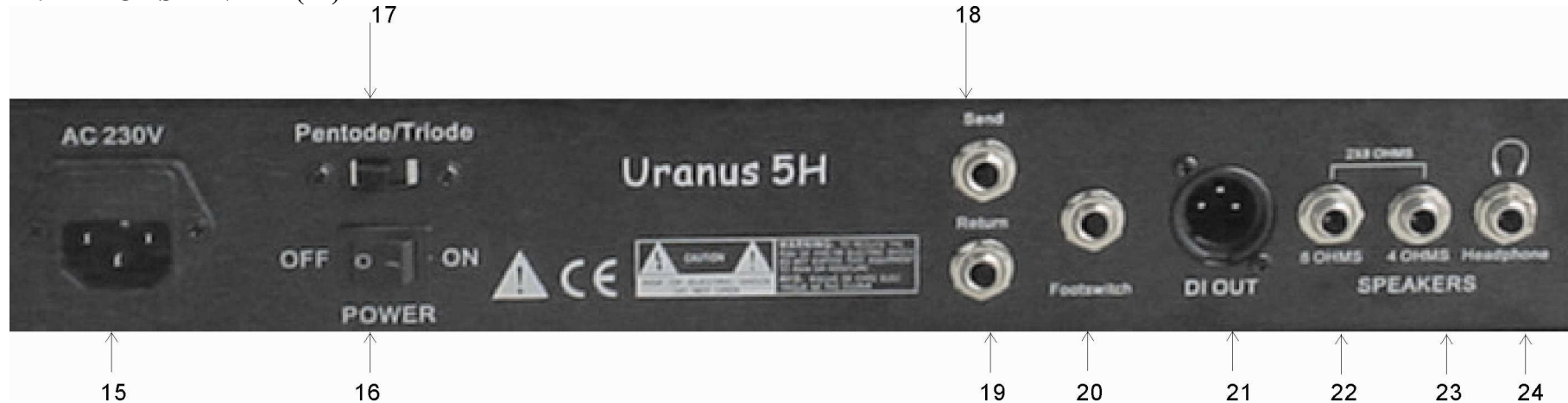

**15. POWER SOCKET: (15)**

**16. POWER ON/OFF: (16)**

**17. PENTODE/TRIODE SW (17)**

15w/7.5w power switch

**18. SEND (18):(EXTERNAL)**

Output sending signal to external effects or signal processing equipment.

**19. RETURN: (19)(EXTERNAL)**

Input returning signal from external effects or signal processing equipment

**20. FOOT SWITCH :(20)(EXRERNAL)**

Connected with the optional remote footswitch. Footswitch is used to select defeat reverb. When using remote foot switch, always insert the plug fully (second click) to ensure proper operation

**21. DI OUTPUT : (21)**

There is dummy load embedded into amp, so when you recording, you can only connect amp with DJ, don't need connect cabinet again.

**22.OUTPUT : (22)**

Provide for connection of external 8ohms speaker cabinet.

### **23. OUTPUT: (23)**

Provide for connection of external 4ohms speaker cabinet.

NOTE: The way connect with speaker

(1) Connect two speakers at same time, The impedance of each speaker must 8ohms

(2) If you only connect one speaker, please connect according to the impedance.

### **24. HEADPHONE: (24)**

There is emulator of speaker embedded into amp, so when you practice in home, you can only connect amp with headphone, don't need connect cabinet again. Even you don't need buy expensive cabinet.

## **SPECIFICATIONS**

### **POWER AMPLIFIER SECTION**

6L6 (EL34)'s with 12AX7 driver

#### **Rated Power &Load**

5w RMS into 8, 4 ohms

#### **Power @Clipping (Typically)**

(5%THD, 1 KHZ, 120v AC line) 5W RMS into 8, 4 ohms (Bias must be reduced to measure)

#### **Frequency Response:**

+0,-2db, 50HZ to 15KHZ,@, 20w RMS into 16 ohms

#### **Hum &Noise:**

Greater than 80 dB below rated power

#### **Power consumption:**

70 wttts , 50/60HZ. 120 VAC (domestic)

### **PREAMP SECTION**

2-12AX7's

The following specs are measured @1KHz with the controls present as follows:

Pre &Post (lead)@0

Reverb Level @0

Bass &Treble EQ @12

Middle [EQ@0](#)

Boost Switch Out

**Nominal Level is with Input Gain @6**

**MINI level is with Input Gain @ 12**

**Preamp Normal Input**

Impedance: Very high Z, 470Kohm

**Lead Channel**

**(Post Gain @ 12)**

Nominal Input level -40dBv, 10mV RMS

MINI Input Level: -70 dBV, 0.3mV RMS

Nominal Input Level:

-17 dBV , 140mV RMS

MINI Input Level: -28dBV, 40mVRMS

Max Input Level: 0dBV 1.0VRMS

**Equalization:**

Customer bass, middle & treble passive-type EQ

**Effect send**

-Load Impedance: 1Kohm or Greater; Nominal Output Level: -6dBV, 0.5V RMS

**Effect Return**

Impedance: High Z, 2M ohms

Designed input Level:

-6dBV ,0.5VRMS (Switching jack provides Effect Send to Effects Return connection when not used

External Footswitch Function:

Reverb Defeat

(when reverb control is raised )

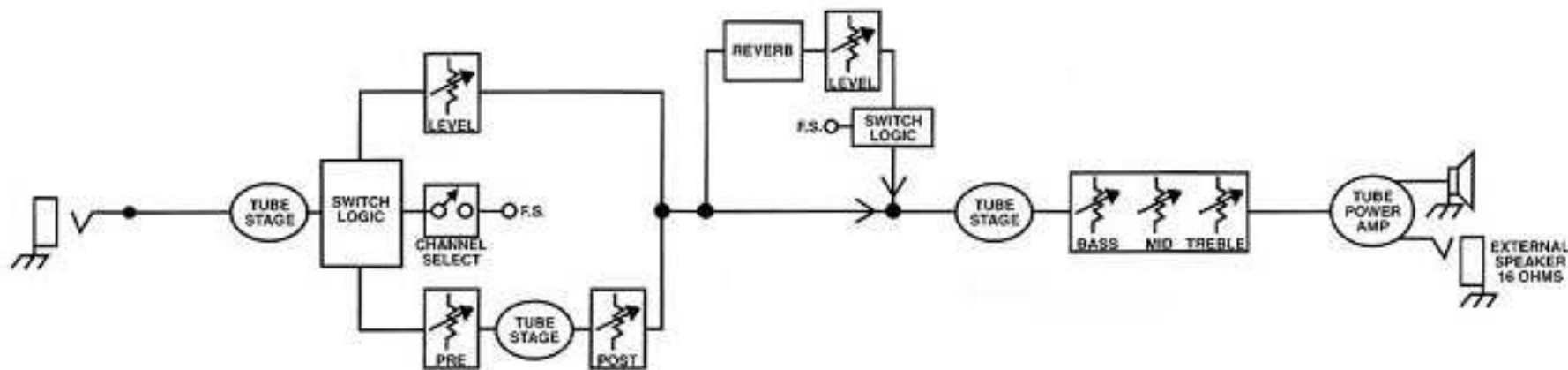

## IMPORTANT SAFETY INSTRUCTIONS

**WARNING:** When using electric products, basic cautions should always be followed.

1. Read all safety and operating instructions before using this product.
2. All safety and operating instructions should be retained for future reference.
3. Obey all cautions in the operating instructions and on the back of the unit.
4. All operating instructions should be followed.
5. This production should not be used near water, i.e.. a bathroom , sink, swimming pool, wet basement, etc.
6. This product should not be placed near a source of heat such as a stove, radiator, or another heat producing amplifier.
7. This product should be located so that its position does not interfere with its proper ventilation. It should not be placed flat against a wall or placed in a built-in enclosure that will impede the flow of cooling air
8. Connect only to a power supply of the type marked on the unit adjacent to the power supply cord.
9. Never break off the ground pin on the power supply cord
10. Power supply cords should always be handle carefully. Never walk or place equipment on power supply cords. Periodically check cords for cuts or signs of stress, especially at the plug and the point where the cord exits the unit.



11. The power supply cord should be unplugged when the unit is to be unused for long periods of time.
12. If this product is to be cleaned with a damp rag. The vinyl covering used on some units can be cleaned with a damp rag or an ammonia-based household cleaner if necessary. Disconnect unit from power supply before cleaning.
13. If the product is to be mounted in equipment rack, rear support should be provided.
14. Care should be taken so that objects do not fall and liquids are not spilled into the unit through the ventilation holes or any other openings.
15. This unit should be checked by a qualified service technician if:
  - A: The power supply cord or plug has been damaged
  - B: Anything has fallen or been spilled into the unit.
  - C: The unit does not operate correctly
  - D: The unit has been dropped or the enclosure damaged.
16. The user should not attempt to service this equipment. All service work should be done by a qualified service technician.
17. Exposure to extremely high noise levels may cause a permanent hearing loss. Individuals vary considerably in susceptibility to noise induced hearing loss. But nearly everyone will lose some hearing if exposed to sufficiently intense noise for a sufficient time.

**SAVE THESE INSTRUCTIONS**